



TWINEAGLES

U S A

Defining the Art of Outdoor Cooking

Twin Eagles 48" Infrared Gas Heater

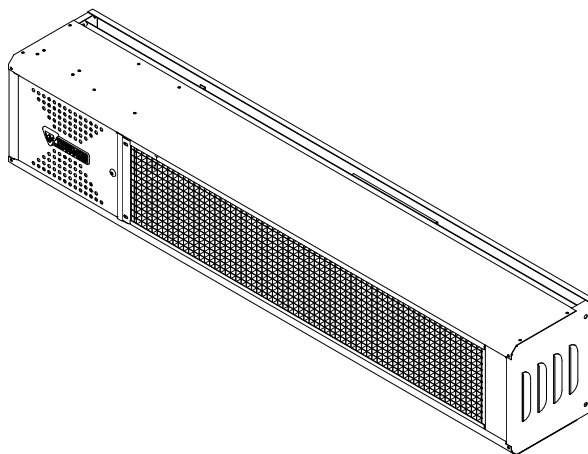

TEGH48-B

Features:

- ▼ 304 Stainless steel construction
- ▼ Two heat settings: High – 37,000 BTU and Low – 25,000 BTU
- ▼ Battery Ignition with 100% safety pilot
- ▼ Wireless Remote Control
- ▼ Decorative safety grill that provides shielding from wind. Wind proof up to 15 MPH
- ▼ No electrical installation required
- ▼ 304 Stainless steel mounting brackets included
- ▼ 36" Flexible gas hose included
- ▼ 120 VAC/ 6 VDC Optional Adapter available (not included)
- ▼ NG and LP conversion kit available
- ▼ 4 AA Batteries included

Specifications:

Overall Dimensions

	TEGH48-B
Height	: 9.00"
Width	: 48.00"
Depth	: 8.00"
Weight	: 50 lbs